

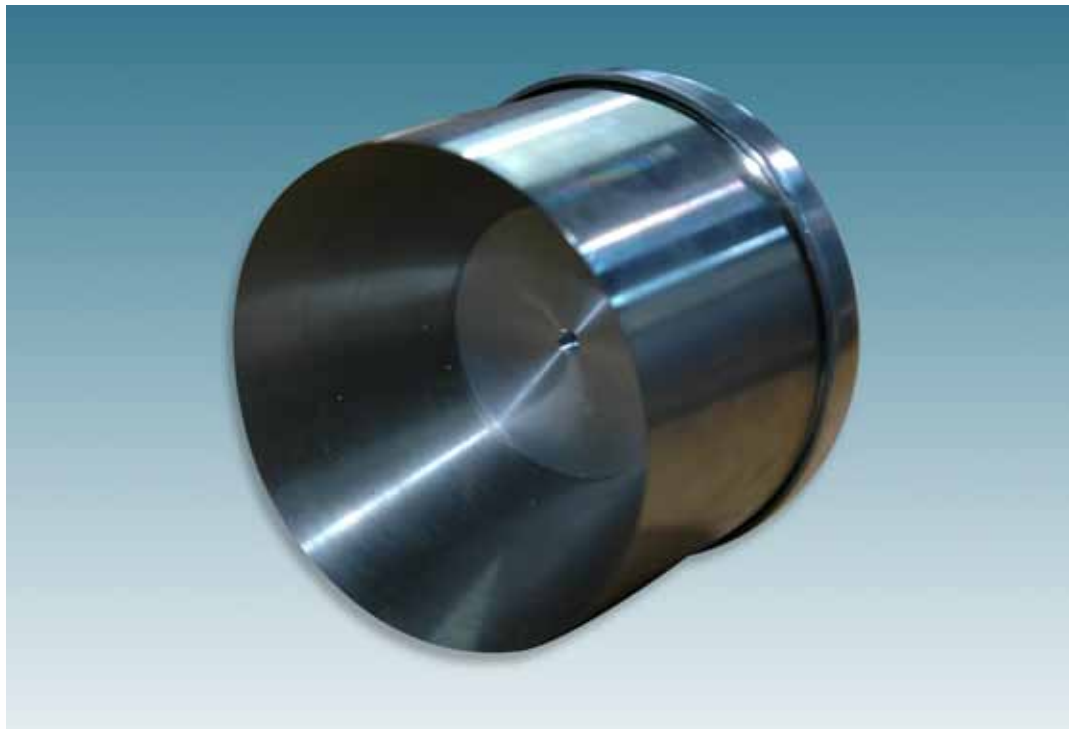

The Sea Vision SV14 weld in model for steel hulls can be installed in the transom or the hull, it utilizes a 250 watt HID metal halide lamp and 110-230 volt AC power. The lights can be welded at adjustable angles to suit all hull shapes. The hull shape and positioning will dictate the angle of the light you require, angles available are 0 to 50 degree. The vessel must be hauled out for installation although lamp change and any maintenance can be done in the water from within the hull.



SV 14 (Steel) 24 degree mount shown.

## SV14 technical specifications

Application for:	Steel hulls	Ballast:	SV34 100-277 VAC 50/60Hz
Lamp:	250 watt HID metal halide	Weight:	6.5 Kg / 14 lbs
Life length:	approx. 3,000 hours plus	Cable:	Only required between the light and ballast. Maximum distance from 15 feet / 4.5 meters to 33 feet / 10 meters (depending on ballast model). High temperature silicone 18/3 shielded copper wire. Normal ships cable can be used from the ballast to the power supply.
Lumens:	17,000	Code:	SV14-SS / 250W
Kelvin colour temp:	8000	Total shipping weight:	Flush - 12 Kg / 26 lbs 10-24 degree - 13 Kg / 29 lbs 24-38 degree - 18 Kg / 40 lbs 38-50 degree - 19 Kg / 42 lbs
Glass lens:	Borosilicate glass	Installation:	Recommended at least 10" (250mm) below the waterline between 3-8 feet (1-2.5 meters) apart <i>This is a guideline only, for specific requirements please contact us.</i>
Thickness:	12.7mm / 0.5"	<i>All information is subject to change without prior notice, please confirm details prior to ordering.</i>	
Diameter:	58.0mm / 2.3"		
Power supply:	120 VAC 50/60Hz input - running current 1.33 amps 230 VAC 50/60Hz input - running current 0.59 amps		
Casing material:	Stainless steel 316 L		
Dimensions:	Flush - 100mm x 175 mm / 4" x 7" 10-24 degree - 100mm x 175 mm / 4" x 7" 24-38 degree - 140mm x 175mm / 5.5" x 7" 38-50 degree - 140mm x 175mm / 5.5" x 7"		
Angles available:	Flush - weight 3.7 kg/8.2 lbs code: SV14 SS flush 10-24 degree - weight 4.5 Kg / 9.9 lbs code: SV14 SS 24 deg 24-38 degree - weight 9.6 Kg / 21.1 lbs code: SV14 SS 38 deg 38-50 degree - weight 10.2 Kg / 22.5 lbs code: SV14 SS 50 deg		

# SV14 Light

120VAC/250W  
240VAC/250W



## **Introduction:**

Congratulations on the purchase of your new weld-in light for **STEEL** hulled vessels. Underwater Lights® USA, LLC takes pride in providing well designed, high quality and thoroughly tested lights that allow you to “enhance your boating experience”. These lights can be installed in your vessel for aesthetics, to attract fish, for security and safety.

## **General Operating Information:**

The 250W, HID, gas discharge lamp used in this light is not an instant re-strike lamp. This means that it must be allowed to cool for approximately 10 to 20 minutes after being shut off before being restarted. HID lamps generally require approximately 2 minutes to reach full brightness and should be left on for a minimum of 10 minutes. Failure to do so may cause the lamp to flicker when it is turned on the next time.

The light can be operated for a brief period of time when the vessel is out of the water, but, it is crucial that the vessel is in the water to ensure proper lamp cooling, however, the light can be operated while the vessel is underway.

Depending upon water clarity conditions, the light beam can reach up to 30 meters (100 feet).

## **General Safety Information:**

This light must be welded into a STEEL hulled vessel in accordance with common ship building practices.

Never try to install or remove this light while the vessel is in the water.

High temperature silicone electrical cable must be used between the light and the ballast, standard ships cable can be used from the A/C power source to the ballast.

Upon proper installation, this light will become part of the vessels grounding and cathodic protection system.

Always disconnect and lock-out power before working on light.

The light should be inspected for moisture every six months.

The light electrical cabling and ballast box should be visually inspected for proper operating condition every six months.

Marine growth should be removed from the glass using a soft brush to allow both heat and illumination to exit the light.

## **Technical Specifications:**

Lamp = 250 Watt - Metal halide - 17,000 Lumens - 8000 Kelvin color temperature - Approximately 3,000 hours life

Glass = Borosilicate glass - 12.7mm (0.5”) thick - 58mm (2.3”) diameter net aperture

Light Common Body Dimensions = 110mm (4.33”) diameter x 180mm (7.0”) long

Smallest Front Flange Dimensions = 100mm (3.94”) diameter x 25mm (0.98”) long

Largest Front Flange Dimensions = 140mm (5.51”) diameter x 213mm (8.39”) long

Construction = Stainless steel - Black anodized marine aluminum alloy

Power supply = 120VAC 50/60Hz input, 2.38 Amps - Minimum operating temperature -30°C (-22°F)

OR

Power supply = 240VAC 50/60Hz input, 1.15 Amps - Minimum operating temperature -30°C (-22°F)

## **Troubleshooting:**

Please contact our technical support staff in Florida at 1-954-760-4447, Monday to Friday from 8:00 am to 5:00 pm EST.

## **Warranty:**

Underwater Lights® USA, LLC warrants this light to be free from defects in workmanship and materials for a period of two years from the date of original purchase (except lamps). Further, misuse, abuse, improper installation, neglect, improper shipping, damage caused by disasters such as fire, flood and lightning, unauthorized repair or modifications will void said warranty. Should your light prove defective during the warranty period, promptly contact Underwater Lights® USA, LLC for an RMA number and then return the light freight prepaid with the RMA number clearly marked on the outside of the shipping container.

Underwater Lights USA, LLC  
1881 W State Road 84, Bay 102  
Fort Lauderdale, FL 33315 USA  
Phone: 1-954-760-4447  
Fax: 1-954-525-3261  
Internet: [www.seavision.com](http://www.seavision.com)  
Email: [sales@seavision.com](mailto:sales@seavision.com)

DOC:071505-3

Underwater Lights Europe Sarl  
Résidence L'Hippocampe: 19, Avenue Thiers  
06600 Antibes, France  
Phone: 33-(0)-4-97-21-02-96  
Fax: 33-(0)-4-97-21-10-96  
Internet: [www.seavision.com](http://www.seavision.com)  
Email: [sales@seavisioneurope.com](mailto:sales@seavisioneurope.com)

# SV14 Light

120VAC/250W  
240VAC/250W



## Installation:

This light should be installed at minimum 250-300mm (10-12") below the light load water line by qualified/approved personnel using proper tools, welding procedures and materials. An access area of at least 75mm (3") should be left behind the light for lamp servicing and general ventilation.

After selecting a location, cut an appropriate sized hole through the vessel hull. Note: Hole size will be defined by the specific weld-in Front Flange (21) that came with the light. Caution! Check that no electrical wiring, fuel lines, oil lines, water lines etc., pass near or through the intended hole location.

Place the supplied Front Flange (21) into said hole and following common ship building practices, permanently weld-in place. Note: Leave the factory installed block-off disk and protective cap on the supplied Front Flange (21) until final light assembly.

Final light assembly - Remove Front Flange (21) block-off disk, protective cap and clean all surfaces. Install two Glass Gaskets (7) (one gasket on either side of glass) Glass (6) and Glass Retaining Ring (3) using six fasteners (14) tightened in a criss-cross pattern to 9 Nm (7 ft/lbs) using a 5mm allen wrench. Screw the Connecting Ring (2) with attached Main Body (1) onto the Front Flange (21) and tighten to 40 Nm (30 ft/lbs). Note: Apply anti-seize compound to Connecting Ring (2) threads. After making proper electrical connections (see ballast manual), attach the Projector Lid (5) to the Main Body (1) using six Nuts (17) tightened to 2 Nm (1.5 ft/lbs). Note: Upon completing light installation, it is highly recommended that the Front Flange (21) be coated with antifouling paint.

## Serviceable Parts:

Lamp replacement is done by removing six Nuts (17), removing the Projector Lid (5), pulling the Lamp (11) out of the Lamp Socket (10), pushing a new Lamp (11) into the Lamp Socket (10) and then reversing said procedure. Note: Tighten the six Nuts (17) to 2 Nm (1.5 ft/lbs). Caution! Ensure that the new lamp is clean and free of dust, dirt, grease, oil, water and finger prints.

Glass (6) replacement is done by removing six Nuts (17), Projector Lid (5), Connecting Ring (2) with attached Main Body (1), six fasteners (14), Glass Retaining Ring (3) and Glass Gaskets (7) while the boat is out of the water. Upon thoroughly cleaning all surfaces, reverse said procedure to assemble the new Glass (6) and Glass Gaskets (7). Note: Tighten the six fasteners (14) in a criss-cross pattern to 9 Nm (7 ft/lbs) using a 5mm allen wrench.

MODEL B14_12A12-16A18A, 120VAC OR 240VAC, 250W		
BALLOON	PART	DESCRIPTION
1	14001	MAIN BODY
2	14002	CONNECTING RING
3	14004	GLASS RETAINING RING
4	14005	REFLECTOR
5	14006	PROJECTOR LID
6	14007	GLASS
7	14008	GLASS GASKET
8	14009	CONNECTING RING GASKET
9	14010	PROJECTOR LID O-RING
10	14011	LAMP SOCKET
11	14058	LAMP, 250 WATT
12	14013	PORCELAIN TERMINAL BLOCK
13	14014	CABLE STRAIN RELIEF
14	14015	M6 x 1.0 x 14LG SST SHCS
15	14055	M3 x 0.5 x 20LG SST SHCS
16	14018	M6 x 1.0 x 25LG SST SET SCREW
17	14019	M6 x 1.0 SST HEX LOCKNUT
18	14051	STAND-OFF
19	14052	M4 x 0.7 x 35LG SST SHCS
20	14063	LAMP SOCKET SPACER
21	N/A	CALL TECHNICAL SUPPORT FOR APPROPRIATE FRONT FLANGE

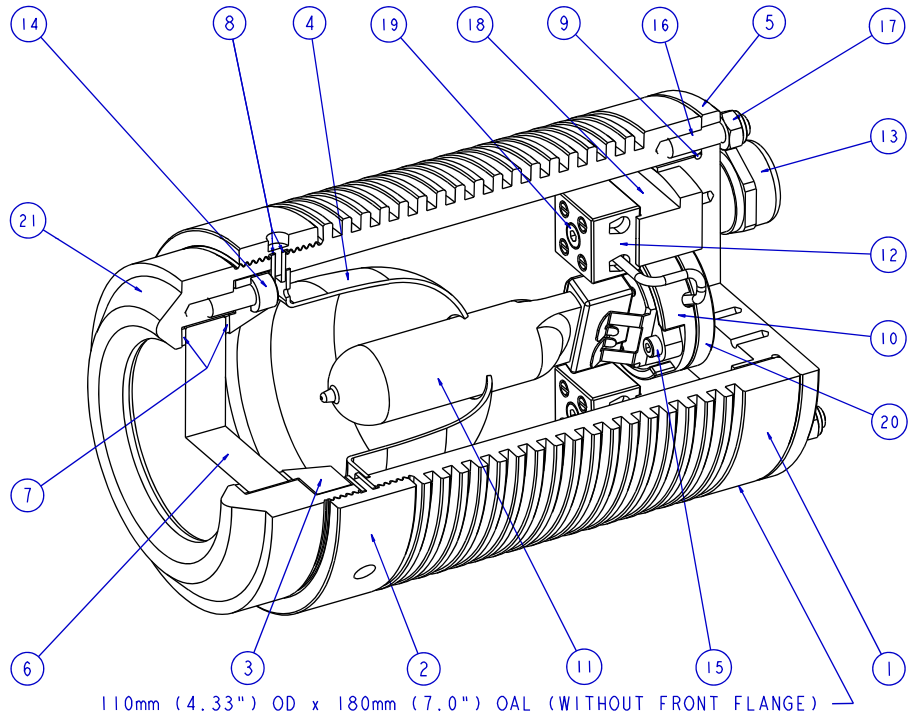

Underwater Lights USA, LLC  
1881 W State Road 84, Bay 102  
Fort Lauderdale, FL 33315 USA  
Phone: 1-954-760-4447  
Fax: 1-954-525-3261  
Internet: [www.seavision.com](http://www.seavision.com)  
Email: [sales@seavision.com](mailto:sales@seavision.com)

DOC:071505-3

Underwater Lights Europe Sarl  
Résidence L'Hippocampe: 19, Avenue Thiers  
06600 Antibes, France  
Phone: 33-(0)-4-97-21-02-96  
Fax: 33-(0)-4-97-21-10-96  
Internet: [www.seavision.com](http://www.seavision.com)  
Email: [sales@seavisioneurope.com](mailto:sales@seavisioneurope.com)

## Weld-in Front Flange Selection for **STEEL** Hulled Vessels

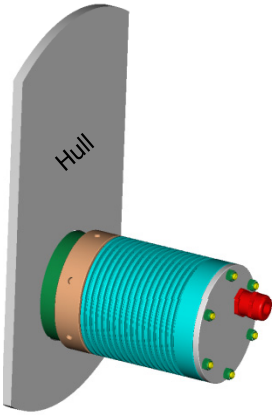

*Light with 0° to 10°  
SS Front Flange  
(14020)*

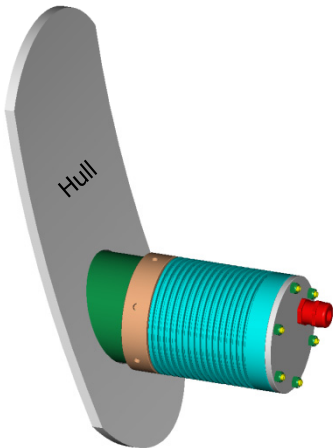
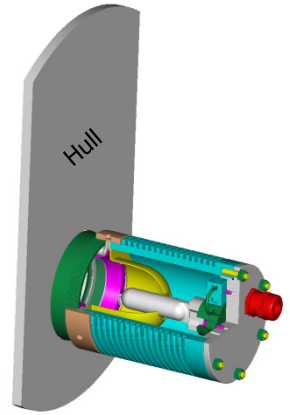

*Light with 10° to 24°  
SS Front Flange  
(14025)*

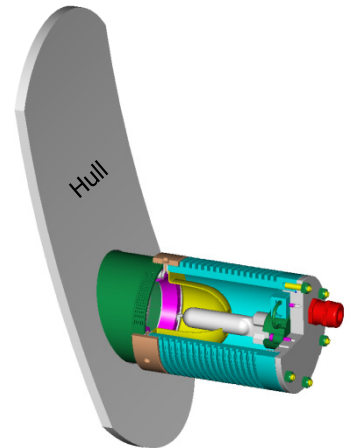

## Weld-in Front Flange Selection for **STEEL** Hulled Vessels

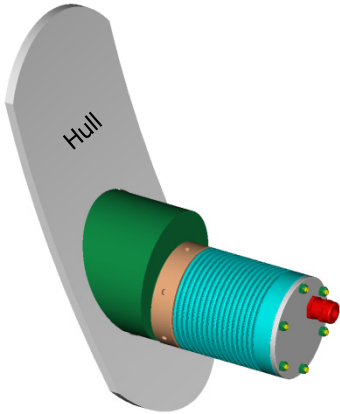

*Light with 24° to 38°  
SS Front Flange  
(14030)*

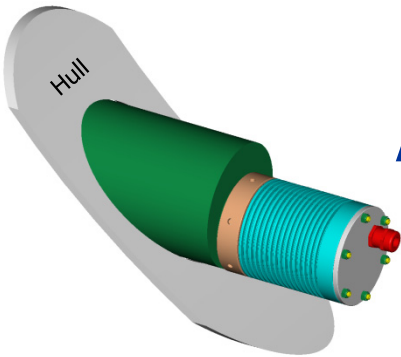
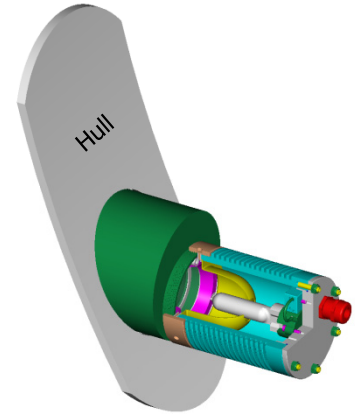

*Light with 38° to 50°  
SS Front Flange  
(14035)*

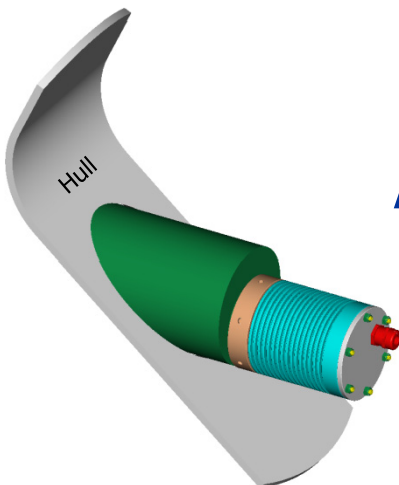
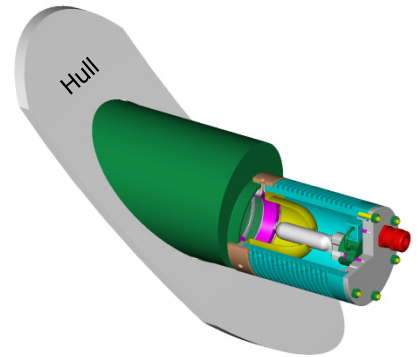

*Light with 38° to 50°  
SS Front Flange  
(in hull bottom)*

